

NOTES:

1. TOOL JOINTS SHALL BE PLACED EVERY 5 FEET AND MATCH CURB JOINTS.
2. EXPANSION JOINTS SHALL BE PLACED EVERY 20 FEET IN THE SIDEWALK, BETWEEN THE SIDEWALK AND BOARDING/ALIGHTING AREA, AND BETWEEN THE SIDEWALK AND BENCH/CLEAR SPACE AREA. FELT EXPANSION MATERIAL SHALL EXTEND THE FULL SIDEWALK DEPTH.
3. 2% MAX SLOPE FOR CLEAR SPACES AND BOARDING AREAS PERPENDICULAR TO ROADWAY. MATCH CURB SLOPE PARALLEL TO ROADWAY.
4. WITH ROLLED CURB AND GUTTER, THE INSIDE PED RAMP FLAIR IS REDUCED FROM A 6FT WING TO A 3FT WING.
5. TACTILE WARNING SURFACES ARE REQUIRED PER SD 2013.
6. FINISHED WORK EXCEEDING MAXIMUM SLOPES OR LESS THAN MINIMUM DIMENSIONS WILL BE REJECTED. MAXIMUM AND MINIMUM VALUES ARE ABSOLUTE.

TYPICAL CROSS SECTION

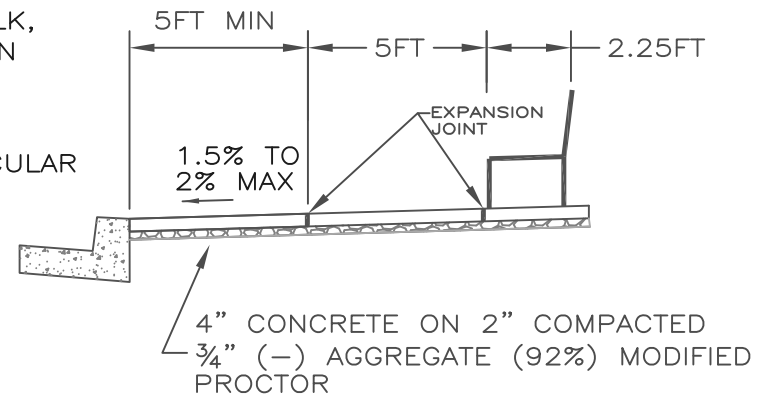

APPROVED BY:

POST FALLS STANDARDS FOR PUBLIC WORKS CONSTRUCTION

[Signature] 3/19/19
 CITY ENGINEER, P.E. DATE:

BUS STOP IN PLANTER STRIP

STANDARD DRAWING
 NO. BD 2